

PLAN VIEW

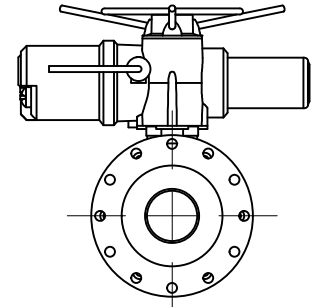

FRONT VIEW

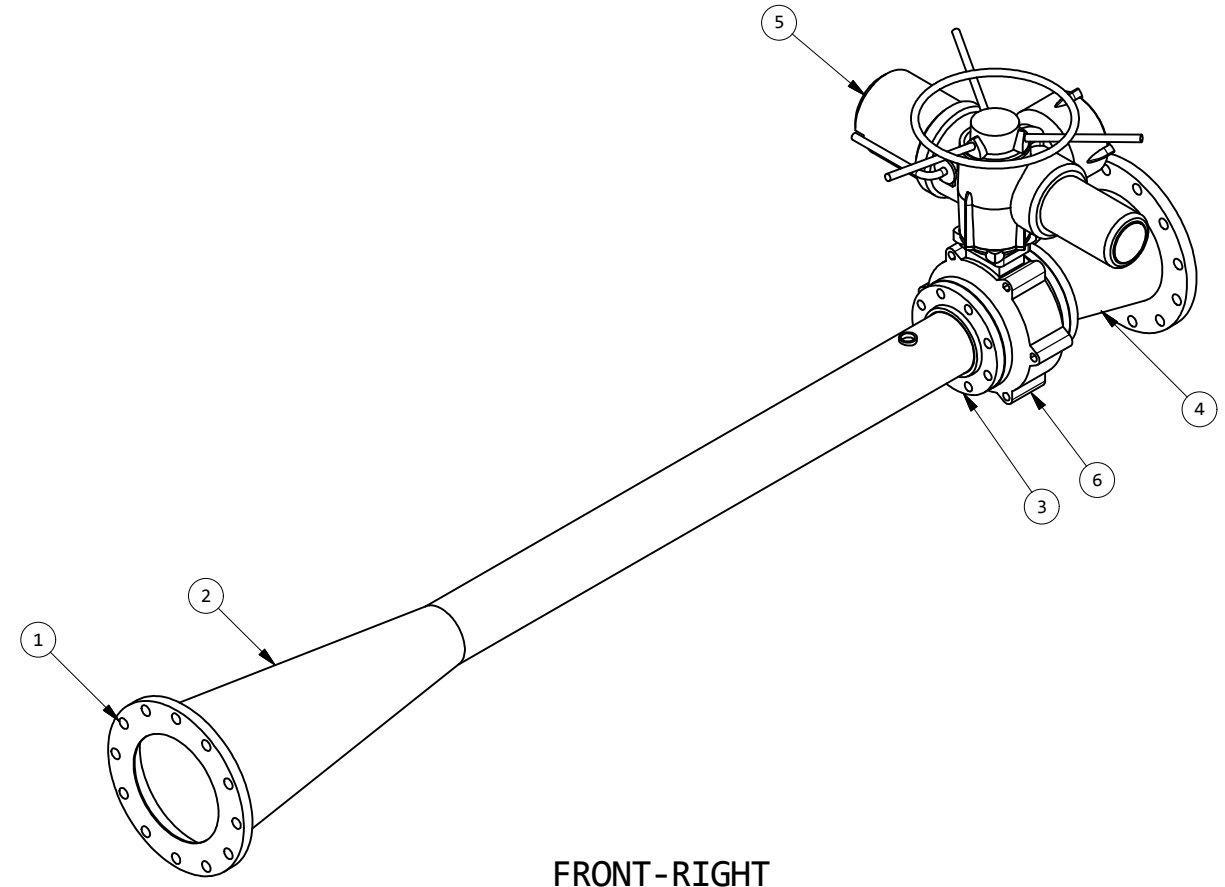

FRONT-RIGHT
1/16 SCALE

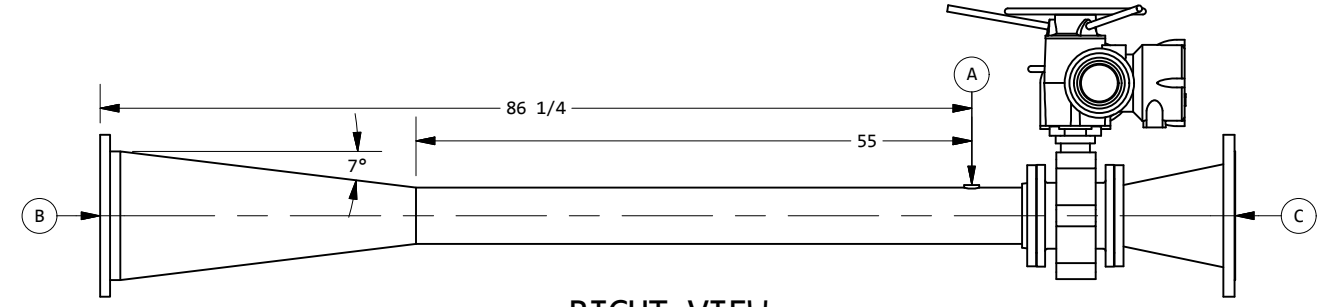

RIGHT VIEW

CONNECTION LIST			
CONN.	DESCRIPTION	SIZE	TYPE
A	FLOWMETER CONNECTION	1"	FNPT
B	INLET	10"	FLANGE
C	DISCHARGE	10"	FLANGE

PARTS LIST			
ITEM	QTY	TAG	DESCRIPTION
1	1		10" Van Stone Flange, Self-Aligning
2	1		7 Degree Reducer, 316L, SCH 10
3	1		Slip-on Weld Flange, 5", Class XXX, 316L
4	1		10"X5" Flanged Reducer - Class 150, 316L
5	1		Rotork Actuator, IQ2 series, 5" Flanged Connections
6	1		5" Rotork Iris Valve, DN125

- :
- UNITS ARE IN INCHES UNLESS OTHERWISE NOTED.
 - PIPING TO BE 316L, SCH. 10S
 - QUANTITY (1) REQUIRED.

PROFLOW S/N 102010001

REL	DATE	PM	ENG	DRFT	DESCRIPTION OF ISSUE	CHK	APP'D
1	3/13/2018	W3	WN	W3	RELEASED FOR APPROVAL		

DESTROY ALL PREVIOUS PRINTS

EGGER	EGGER
FLOW CONTROL 10"X5" PIPE SPOOL GENERAL ARRANGEMENT	140 WILLINGHAM DRIVE - JULIETTE, GA 31046 THIS PRINT AND THE INFORMATION CONTAINED WITHIN IT ARE THE PROPERTY OF PROFLOW, INC. IT IS CONSIDERED PROPRIETARY IN NATURE AND MAY NOT BE USED OR DISCLOSED OUTSIDE OF PROFLOW, INC EXCEPT UNDER PRIOR WRITTEN AGREEMENT.
	TOLERANCES X ±0.1 XX ±0.01 XXX ±0.005 ANGLES ±0.030° FRACTIONS ±1/16
DWG. #:	10201020
SCALE:	1/19 B 1

ProFlow Inc Inventor Dwg. File No.: 102010201